

# Would prompt work for graph learning? An exploration of few-shot learning on graphs

**Yuan FANG**

School of Computing and Information Systems  
Singapore Management University

**VALSE Webinar**

**10 Jan 2024**



School of  
**Computing and  
Information Systems**

# Outline

2

- **Introduction: Data and problems**
- Overview of few-shot methodologies
- Can prompt work on graph + text?
- Can prompt work on graph alone?
- Conclusion

# Complex big data as graphs

3

## Social networks

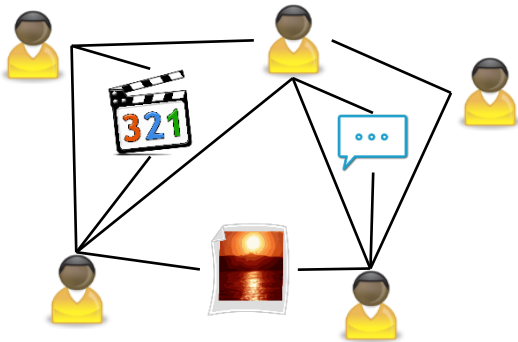

## Biology

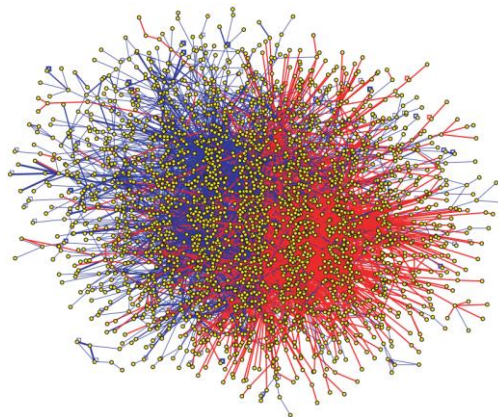

[Image from RVH05]

## E-commerce

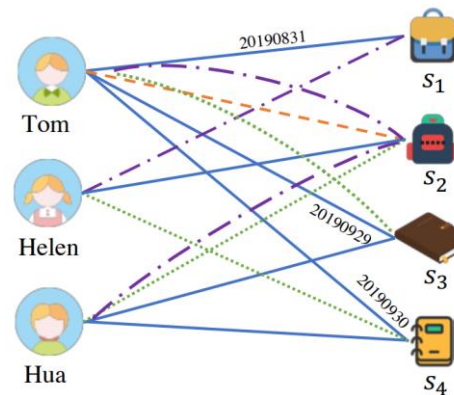

## Knowledge graph



[Image from Microsoft]

# Data, Problems and Methods

4

## Data

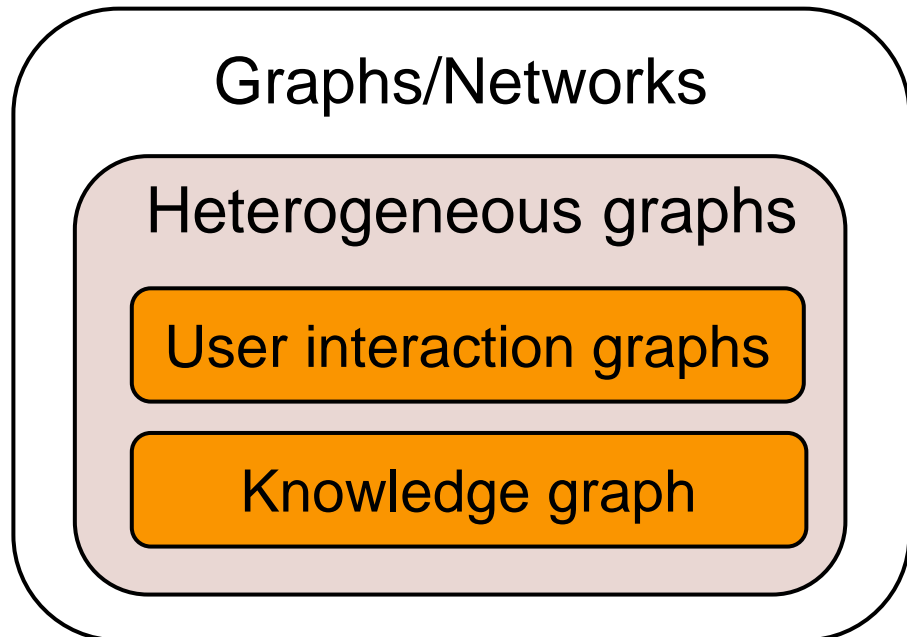

## Problems

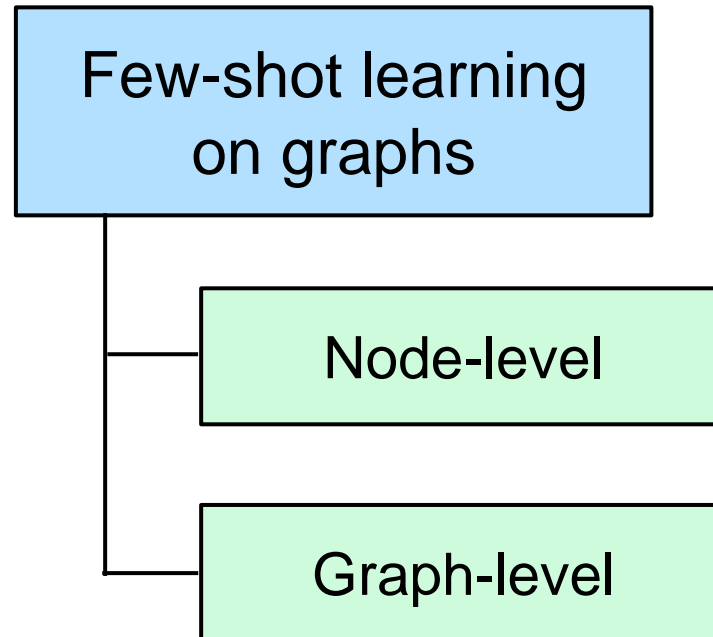

## Methods

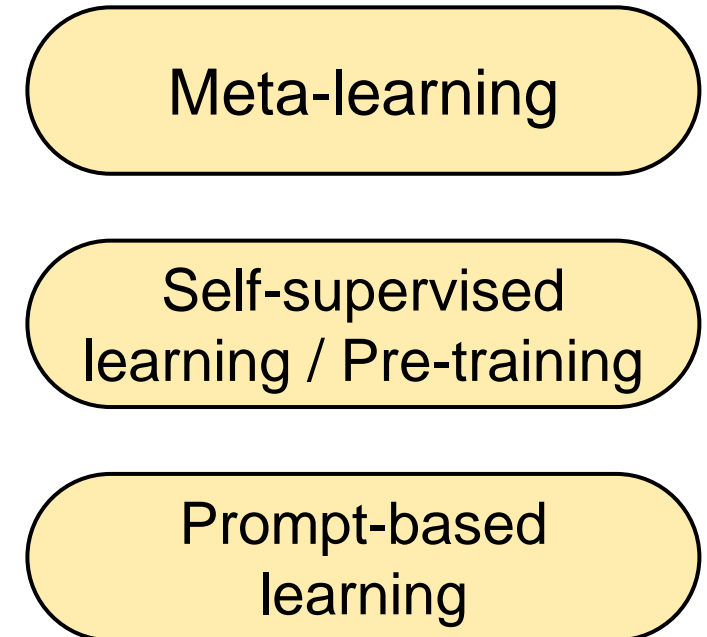

# Few-shot problems on graphs

5

## Node classification

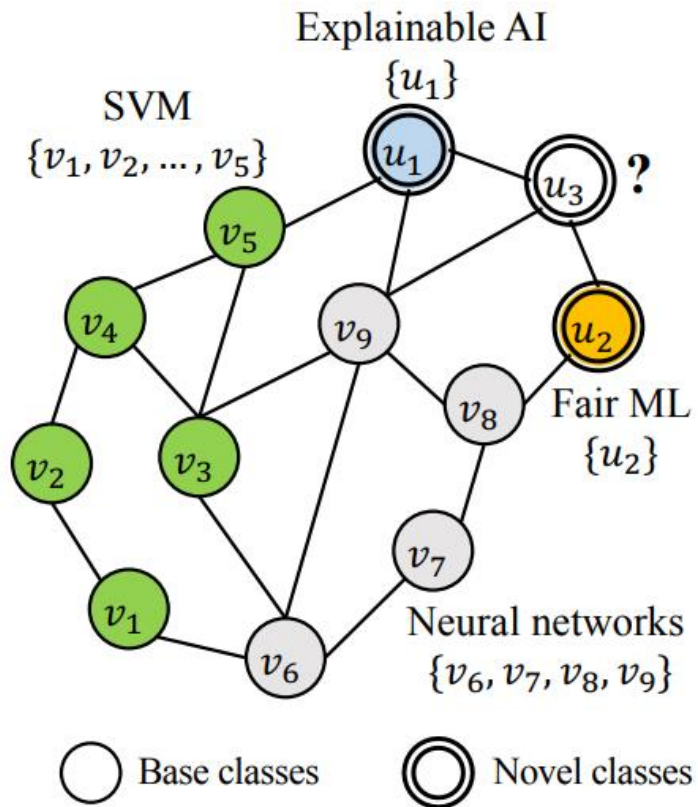

## Graph classification

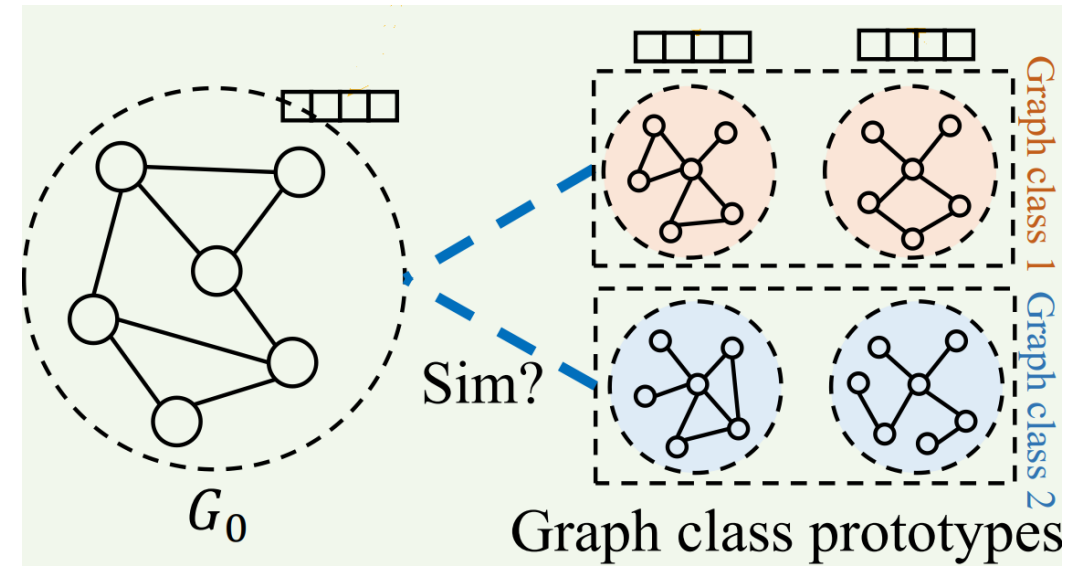

[AAAI21] Z. Liu, Y. Fang, C. Liu and S. C. H. Hoi. *Relative and Absolute Location Embedding for Few-Shot Node Classification on Graph*.

[WWW23] Z. Liu, X. Yu, Y. Fang and X. Zhang. *GraphPrompt: Unifying Pre-Training and Downstream Tasks for Graph Neural Networks*.

# Outline

6

- Introduction: Data and problems
- **Overview of few-shot methodologies**
- Can prompt work on graph + text?
- Can prompt work on graph alone?
- Conclusion

# Why supervised learning does not work?

7

Supervised learning



Learn a classifier

$$f_{\theta}(\text{dog image}) \rightarrow \text{dog}$$

Need many, many labelled data!  
Hard to deal with novel classes.

How humans learn?



One example of toy whale

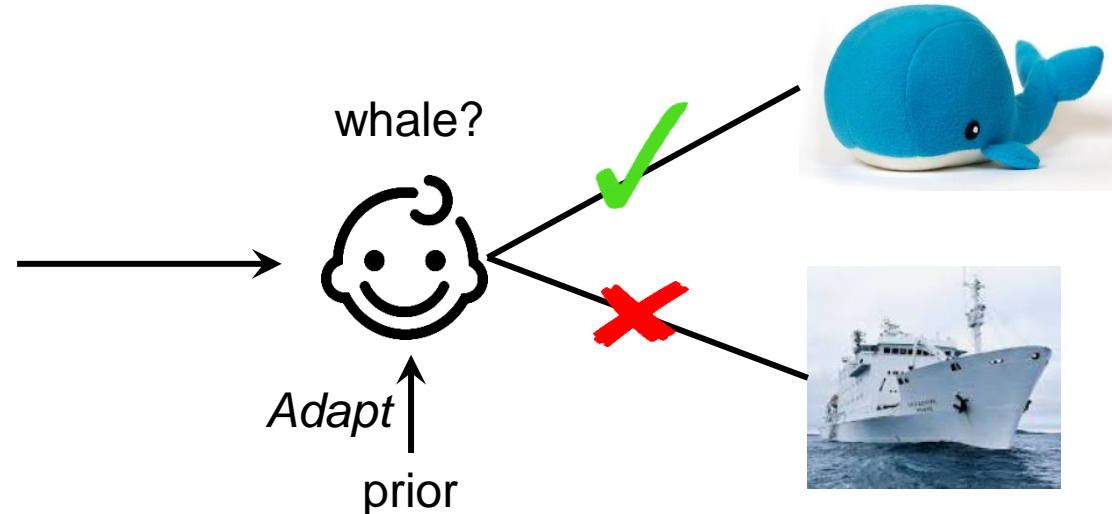

Even toddlers can learn novel classes very quickly with one/few examples... by generalizing from prior knowledge.

# From supervised learning to meta-learning

8

**Supervised learning**

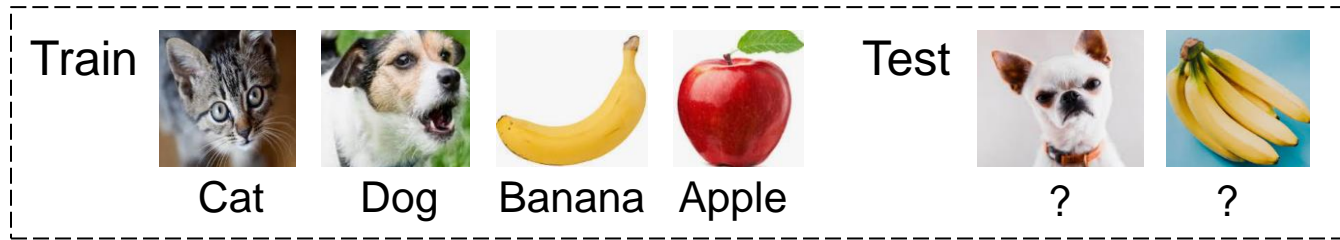

**Meta-learning**  
(MAML [FAL17])

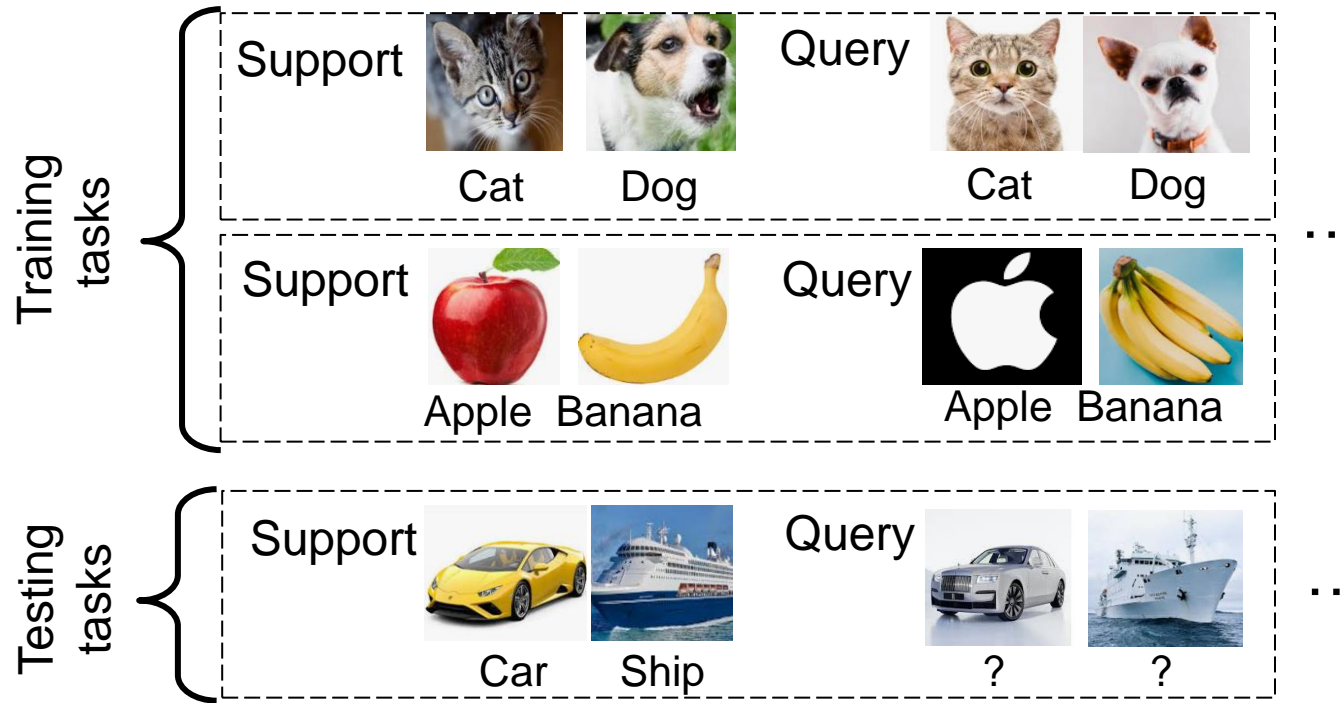

Learn a classifier

$$f_{\theta}(\text{img of dog}) \rightarrow \text{dog}$$

Need many, many labelled data!  
Hard to deal with novel classes.

Learn a prior  $\phi$  from the training tasks

Adapt

$$g_{\phi}(\text{support: Car, Ship}) \rightarrow f_{\phi'}$$

$$f_{\phi'}(\text{img of car}) \rightarrow \text{car}$$

“Learn to learn”



# Self-supervised learning

9

Meta-learning

Training tasks

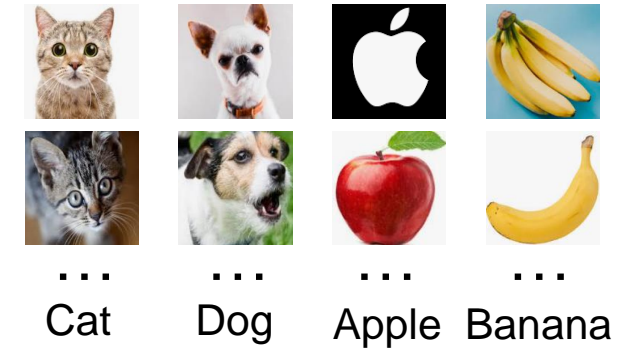
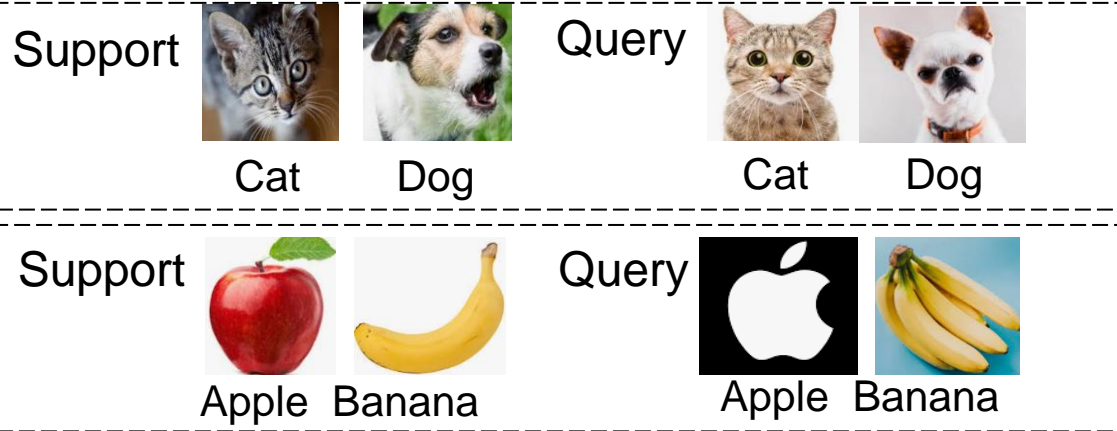

Still require many labels on these base classes to form training tasks

Self-supervised learning

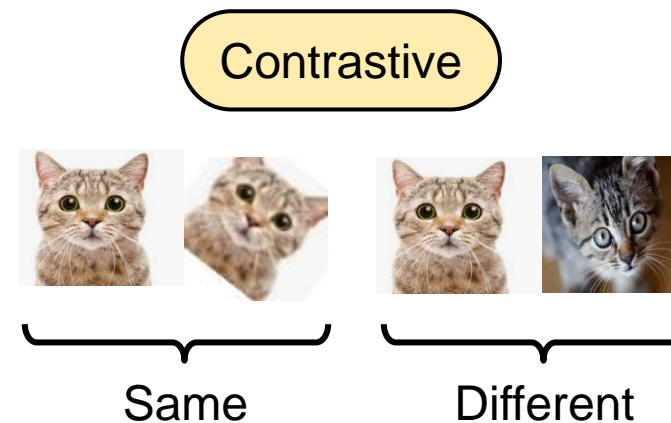
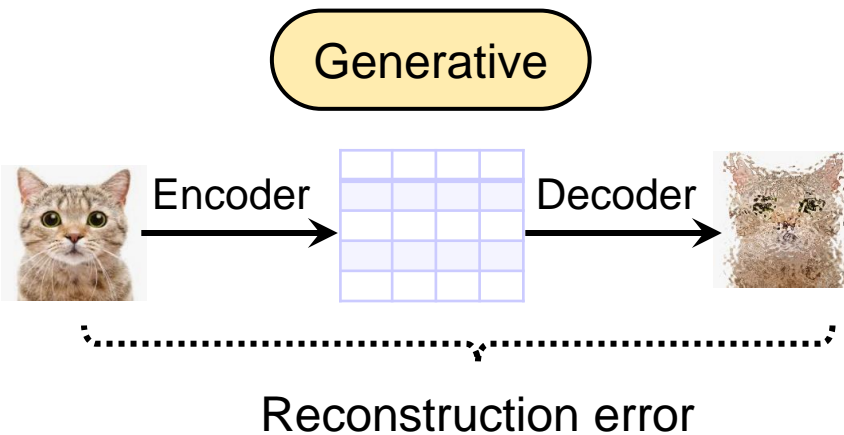

“Free” supervision, no annotation cost!

# Self-supervised learning / Pre-training

10

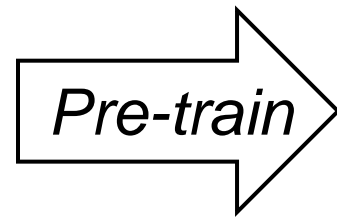
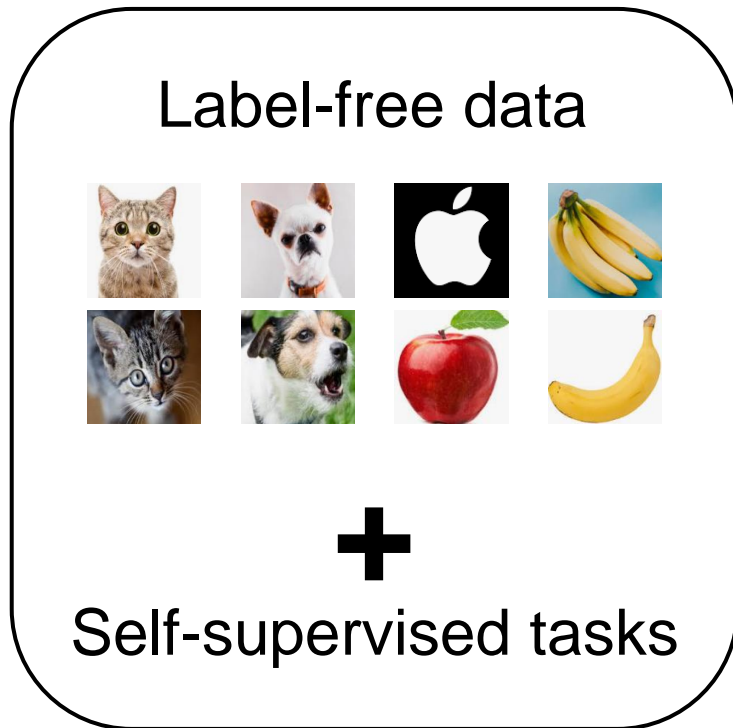

$\theta$



Called "pre-trained model",  
"pre-trained weights", or prior

Downstream tasks  
(with some task-specific labels)

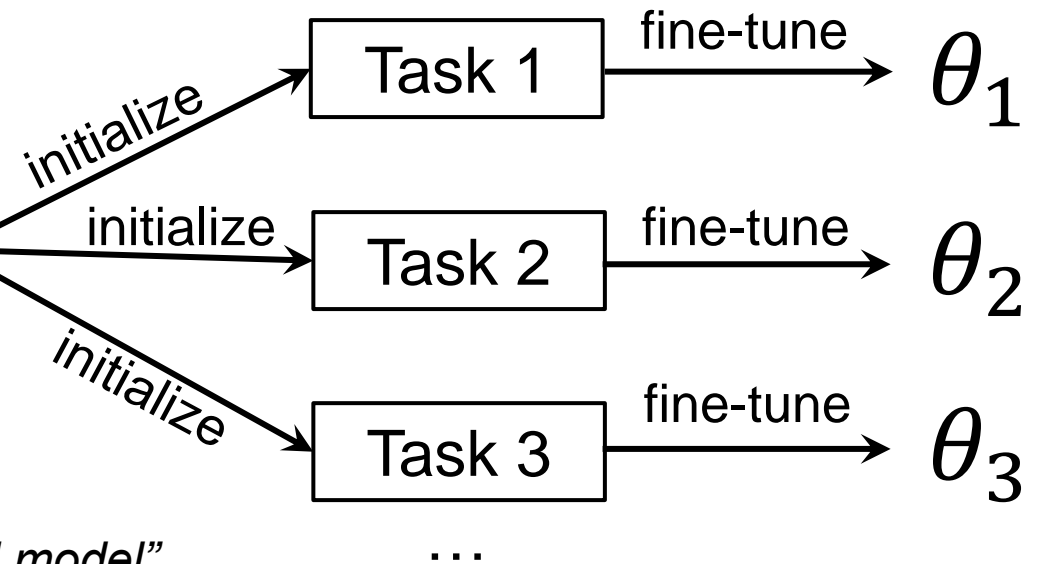

# Graph pre-training: Generative vs. contrastive

11

- Key: Design self-supervised pre-training tasks on graphs

Generative

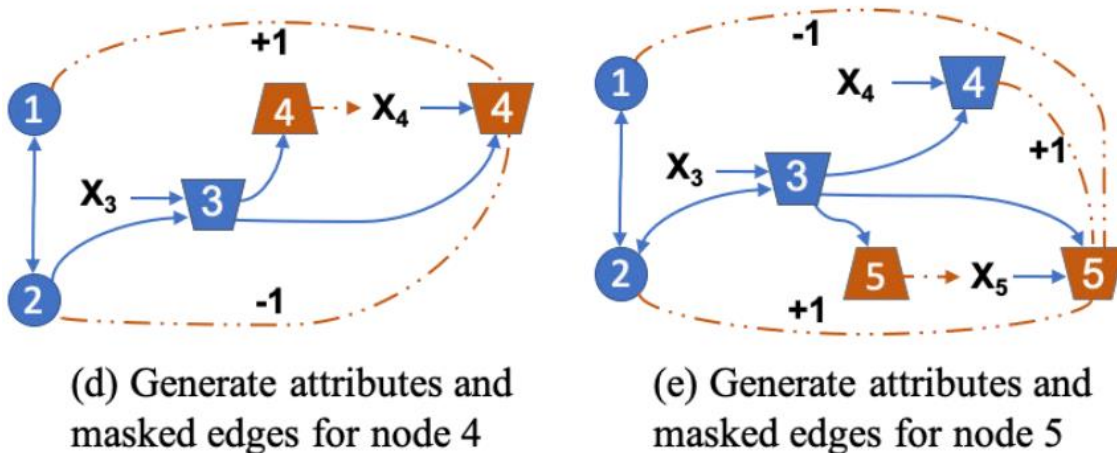

[Image from HDW20]

Contrastive

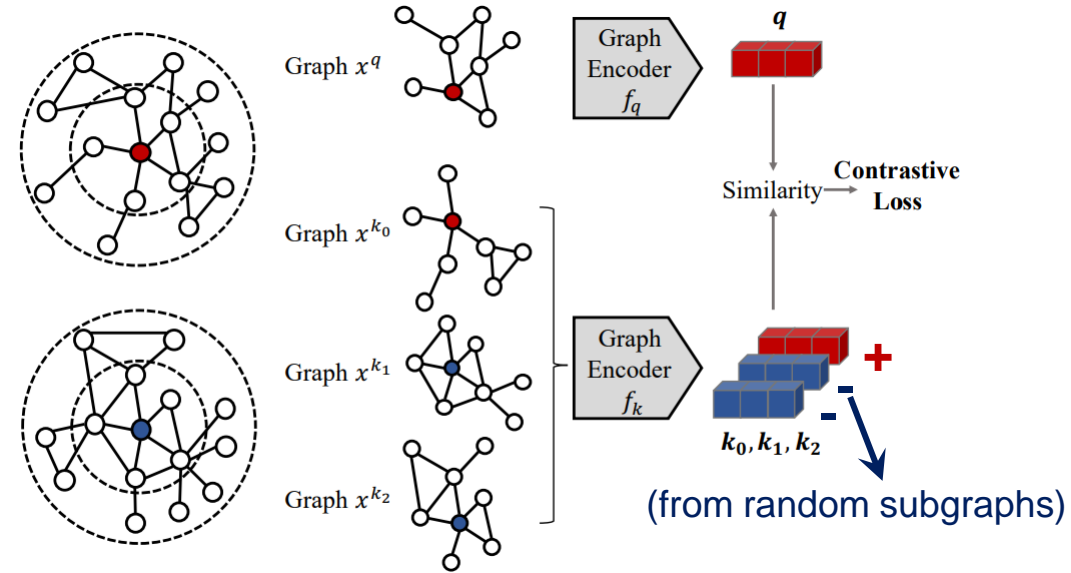

[Image from QCD20]

# Graph pre-training: Spatial vs. Spectral

12

Spatial

Explicit (local) structures and node features

$$\mathbf{H}_a = f(\mathbf{A}, \mathbf{X})$$

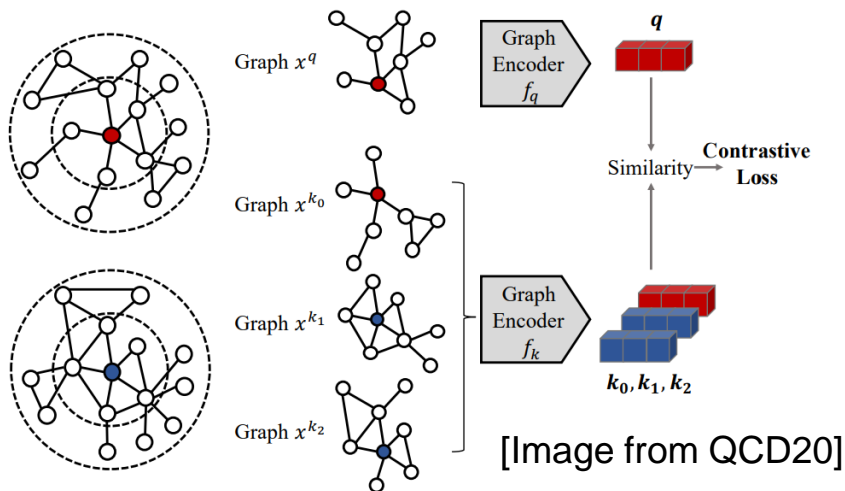

Contrast

Spectral

Implicit node (global) positions on graph topology

$$\mathbf{H}_e = g(\mathbf{\Lambda}, \mathbf{U})$$

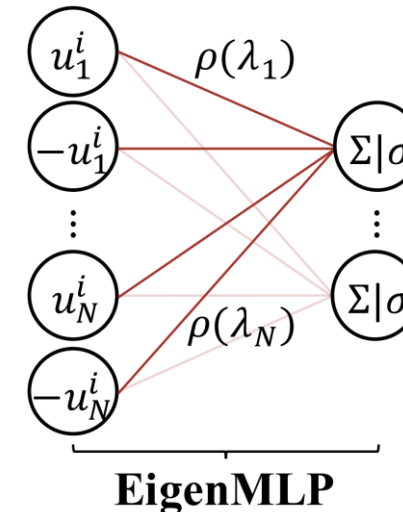

# Pre-training on heterogeneous graphs

13

- Pre-training tasks to capture relation- and subgraph-level semantics

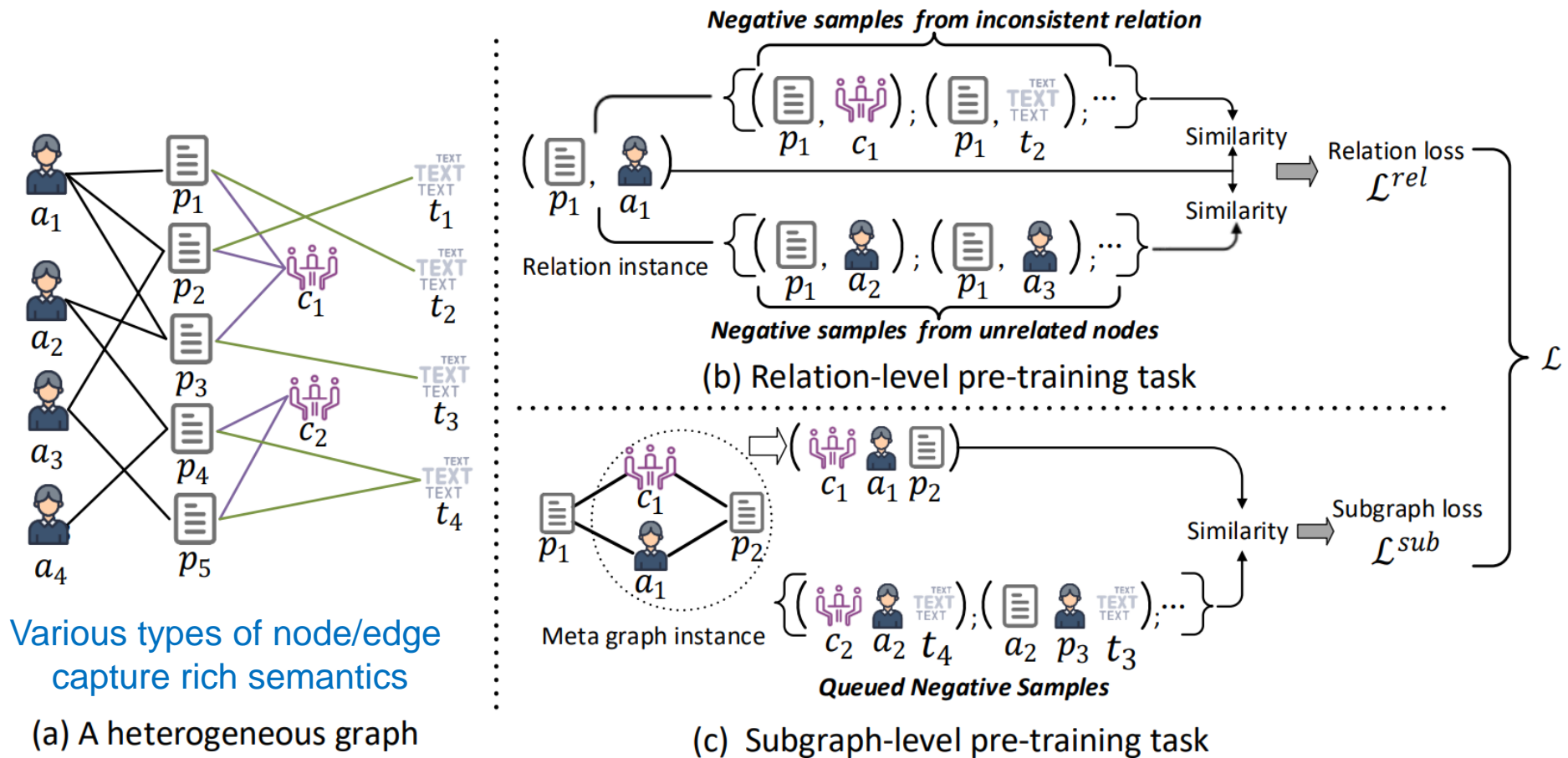

# Pre-training on heterogeneous graphs

14

- Pre-training tasks to capture schema-level semantics

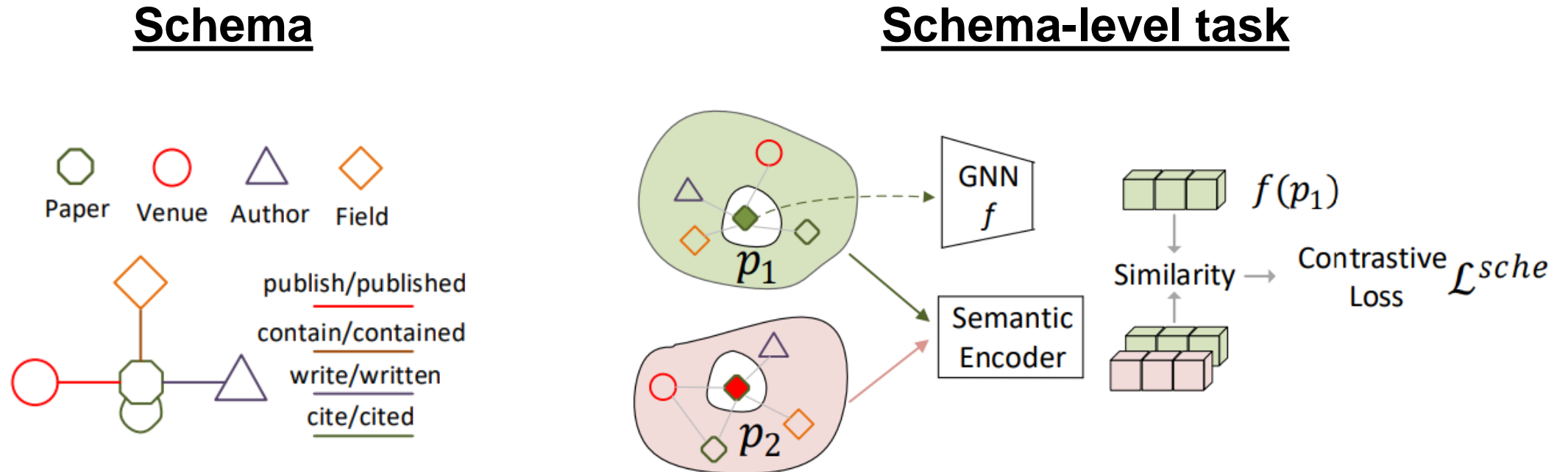

# Problem with pre-training approaches

15

- The gap between pre-training and downstream objectives

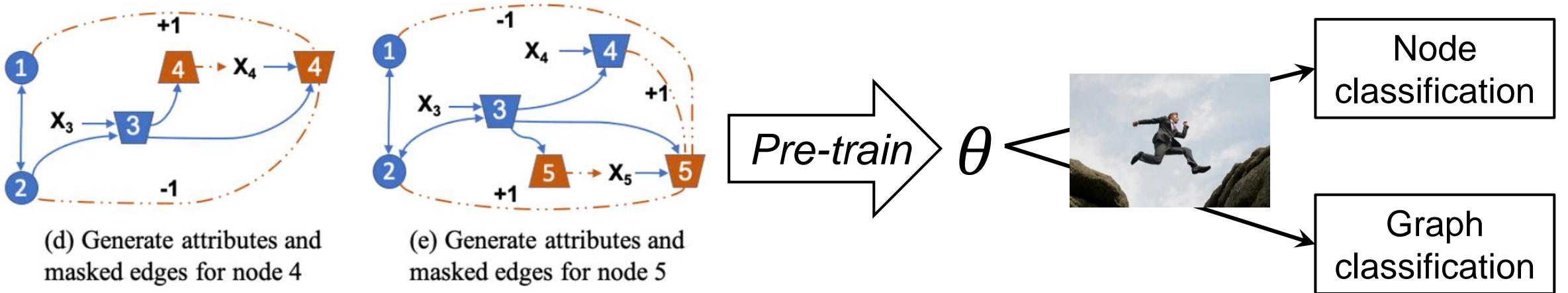

- And the fine-tuning step..
  - ▣ Can be expensive for large pre-trained models
  - ▣ may overfit if there are very few labels from downstream tasks

# Bridging the gap: Pre-train, prompt

16

- **Problem:** Gap between pre-training and downstream tasks
- **Prompt** [LYF23]: an alternative to “pre-train, fine-tune”
  - ▣ Originated in NLP, an instruction to reformulate the original task to unify with pre-trained model (e.g., masked language modeling)

Task: Sentiment classification

“I missed the bus today.”

+ Prompt

“I felt so \_\_\_\_\_”

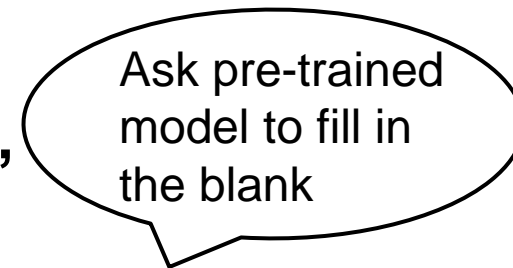

happy +

unlucky -

Zero-shot: Handcrafted (prompt engineering)

Few-shot: Learnable word vectors (prompt tuning)



# Outline

17

- Introduction: Data and problems
- Overview of few-shot methodologies
- **Can prompt work on graph + text?**
- Can prompt work on graph alone?
- Conclusion

# Graph data often associate with texts

18

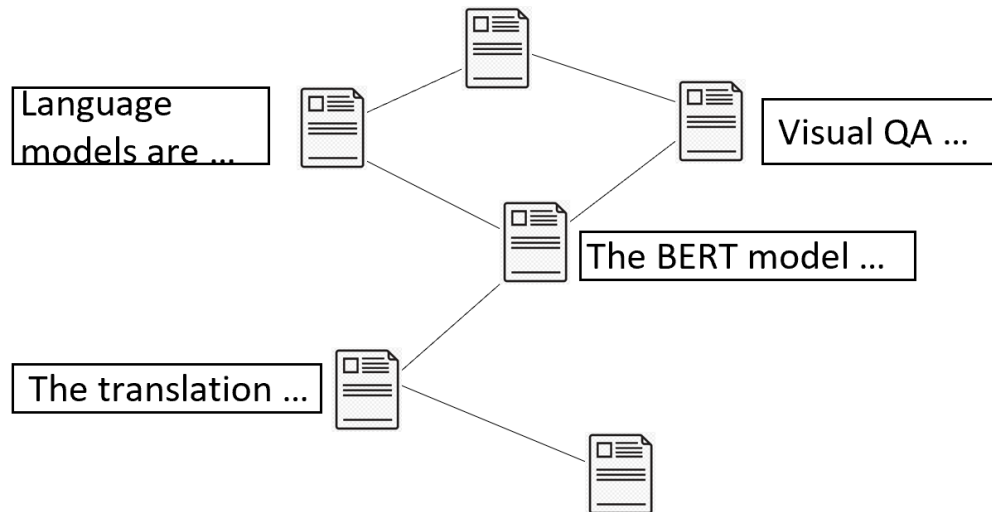

Citation graph for online articles

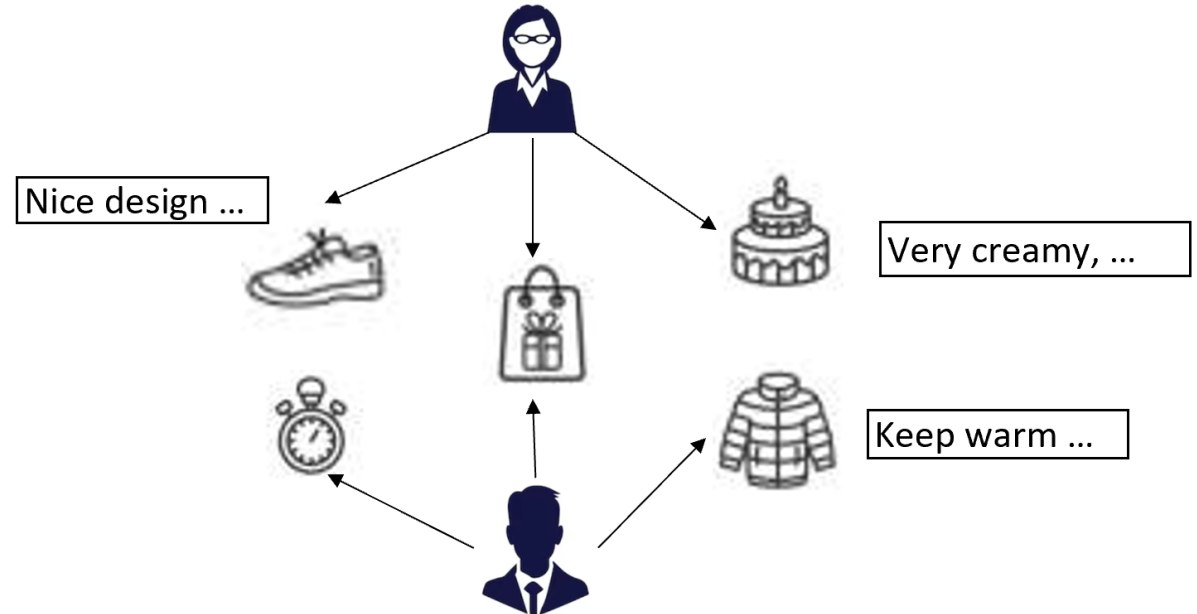

E-commerce item review graph

So, if there is a **jointly pre-trained graph-text model**, we can easily apply natural language-based prompts to graphs.

# Graph-grounded pre-training and prompting (G2P2)

19

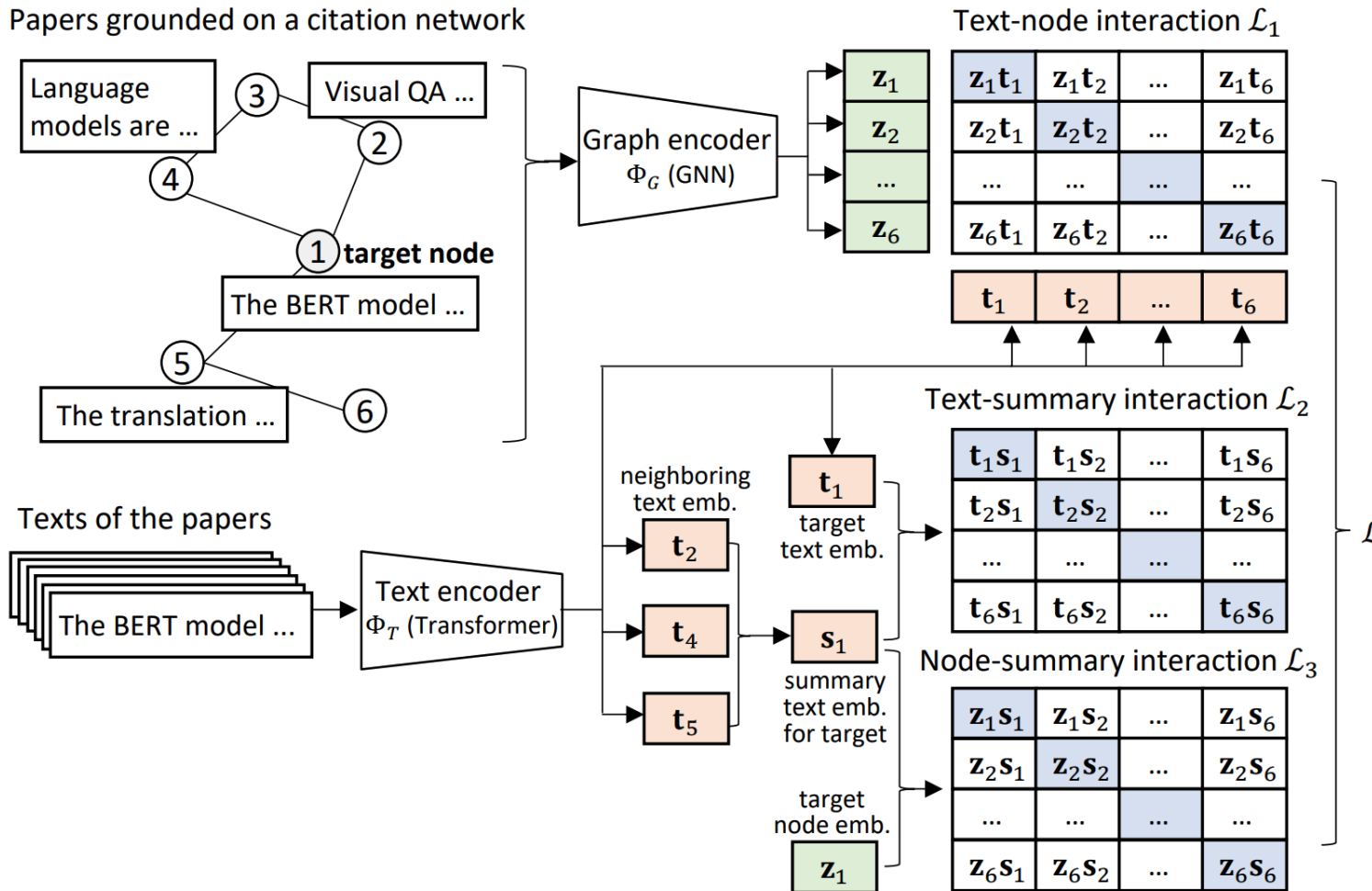

Learns a dual-modal embedding space by jointly training a **text encoder** and **graph encoder**

Exploits **three contrastive strategies**

- Text-node contrast
- Text-summary contrast
- Node-summary contrast

(a) Graph-grounded contrastive pre-training

# Graph-grounded pre-training and prompting (G2P2)

20

## Zero-shot node classification with discrete prompts

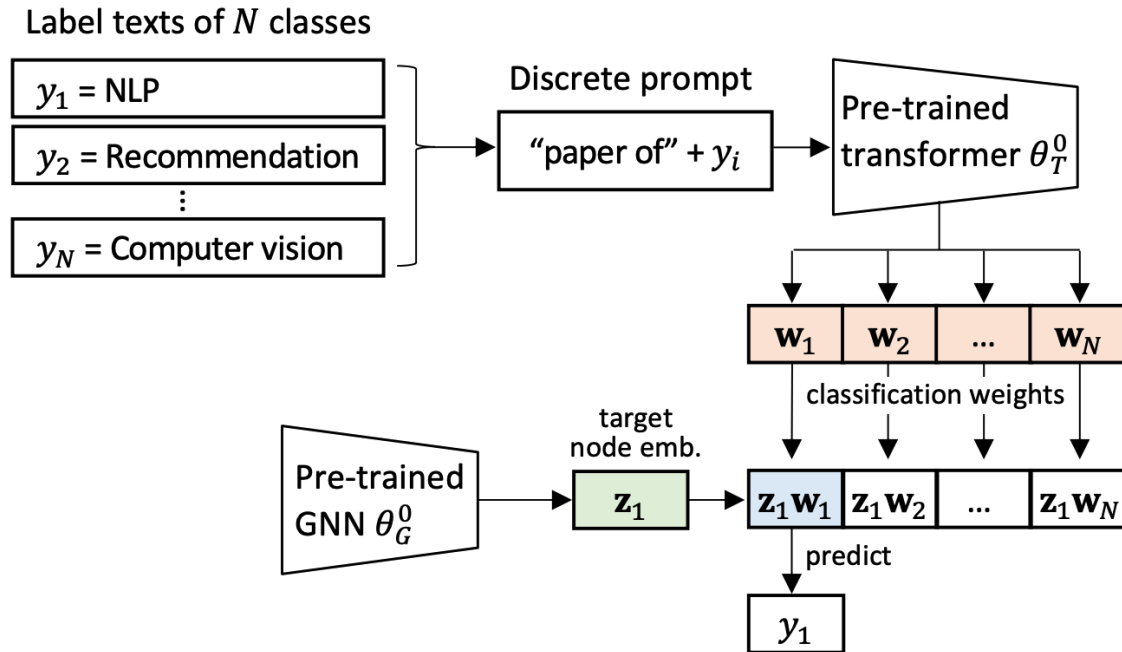

## Few-shot node classification with continuous prompt tuning

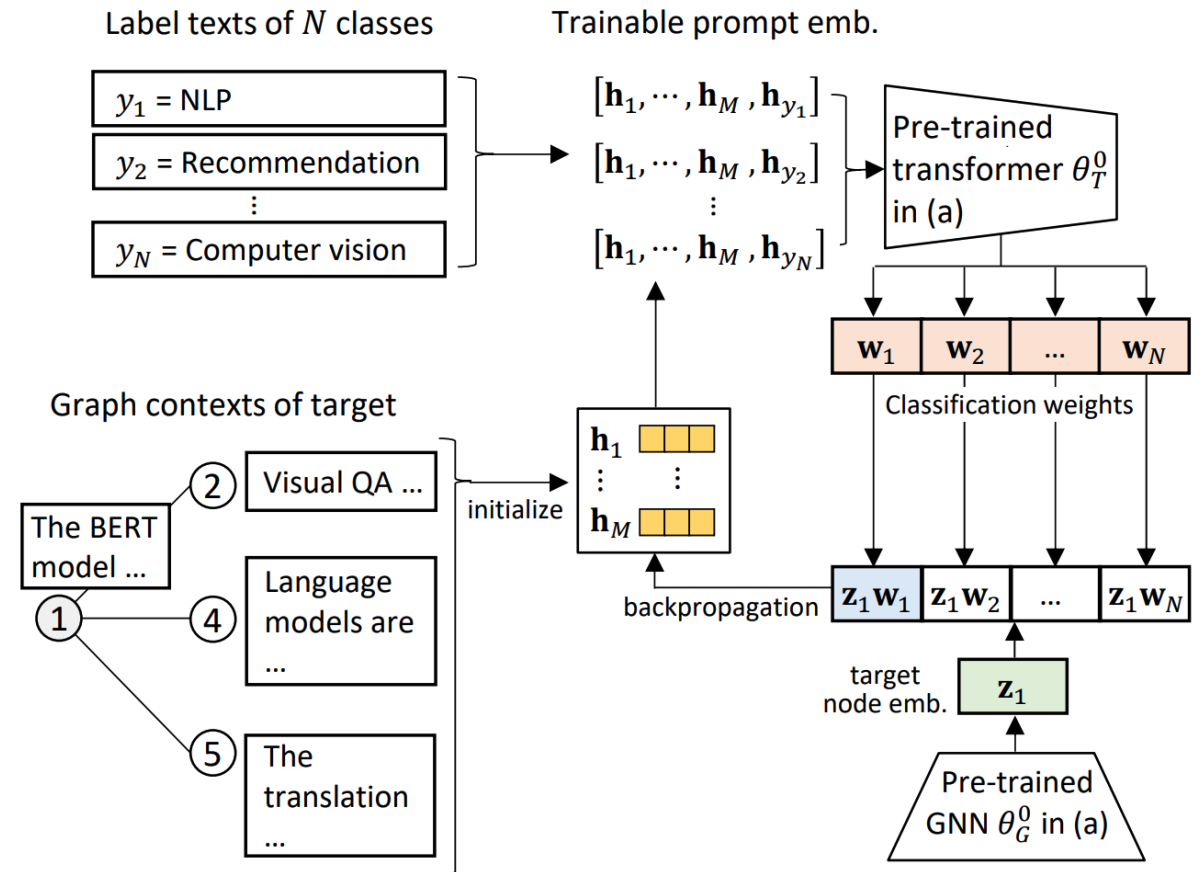

# Datasets to evaluate G2P2

21

Dataset	Cora	Art	Industrial	M.I.
# Documents	25,120	1,615,902	1,260,053	905,453
# Links	182,280	4,898,218	3,101,670	2,692,734
# Avg. doc length	141.26	54.23	52.15	84.66
# Avg. node deg	7.26	3.03	2.46	2.97
# Classes	70	3,347	2,462	1,191

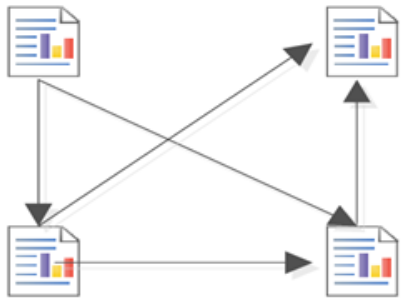

**Cora** is a collection of research papers with citation links

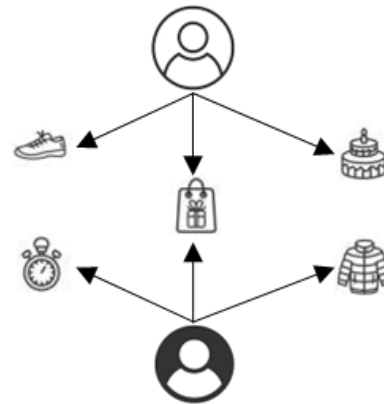

**Art, Industrial and Music Instruments (M.I.)** are three Amazon review datasets

# Empirical performance of G2P2

22

End-to-end  
GNN  
Pre-trained  
GNN  
Pre-trained  
Transformers  
Prompt  
tuning

	Cora		Art		Industrial		M.I.	
	Accuracy	Macro-F1	Accuracy	Macro-F1	Accuracy	Macro-F1	Accuracy	Macro-F1
GCN	41.15±2.41	34.50±2.23	22.47±1.78	15.45±1.14	21.08±0.45	15.23±0.29	22.54±0.82	16.26±0.72
SAGE <sub>sup</sub>	41.42±2.90	35.14±2.14	22.60±0.56	16.01±0.28	20.74±0.91	15.31±0.37	22.14±0.80	16.69±0.62
TextGCN	59.78±1.88	55.85±1.50	43.47±1.02	32.20±1.30	53.60±0.70	45.97±0.49	46.26±0.91	38.75±0.78
GPT-GNN	76.72±2.02	72.23±1.17	65.15±1.37	52.79±0.83	62.13±0.65	54.47±0.67	67.97±2.49	59.89±2.51
DGI	<u>78.42</u> ±1.39	<u>74.58</u> ±1.24	65.41±0.86	53.57±0.75	52.29±0.66	45.26±0.51	68.06±0.73	60.64±0.61
SAGE <sub>self</sub>	77.59±1.71	73.47±1.53	76.13±0.94	65.25±0.31	71.87±0.61	65.09±0.47	<u>77.70</u> ±0.48	<u>70.87</u> ±0.59
BERT	37.86±5.31	32.78±5.01	46.39±1.05	37.07±0.68	54.00±0.20	47.57±0.50	50.14±0.68	42.96±1.02
BERT*	27.22±1.22	23.34±1.11	45.31±0.96	36.28±0.71	49.60±0.27	43.36±0.27	40.19±0.74	33.69±0.72
RoBERTa	62.10±2.77	57.21±2.51	72.95±1.75	62.25±1.33	76.35±0.65	70.49±0.59	70.67±0.87	63.50±1.11
RoBERTa*	67.42±4.35	62.72±3.02	74.47±1.00	63.35±1.09	77.08±1.02	71.44±0.87	74.61±1.08	67.78±0.95
P-Tuning v2	71.00±2.03	66.76±1.95	<u>76.86</u> ±0.59	<u>66.89</u> ±1.14	<u>79.65</u> ±0.38	<u>74.33</u> ±0.37	72.08±0.51	65.44±0.63
G2P2-p	79.16±1.23	74.99±1.35	79.59±0.31	68.26±0.43	80.86±0.40	74.44±0.29	81.26±0.36	74.82±0.45
G2P2	<b>80.08*</b> ±1.33	<b>75.91*</b> ±1.39	<b>81.03*</b> ±0.43	<b>69.86*</b> ±0.67	<b>82.46*</b> ±0.29	<b>76.36*</b> ±0.25	<b>82.77*</b> ±0.32	<b>76.48*</b> ±0.52
(improv.)	(+2.12%)	(+1.78%)	(+5.43%)	(+4.44%)	(+3.53%)	(+2.7%)	(+6.53%)	(+7.92%)

G2P2 outperforms the best baseline by around 3–7%.

# Outline

23

- Introduction: Data and problems
- Overview of few-shot methodologies
- Can prompt work on graph + text?
- **Can prompt work on graph alone?**
- Conclusion

# GraphPrompt: Pre-train, prompt on graph only

24

## Two challenges

- How to unify various pre-training and downstream tasks on graph?
- How to design prompts on graph?

## Insights

- A **unified task template** based on subgraph similarity computation
- Use a **learnable prompt** to guide graph readout for different tasks

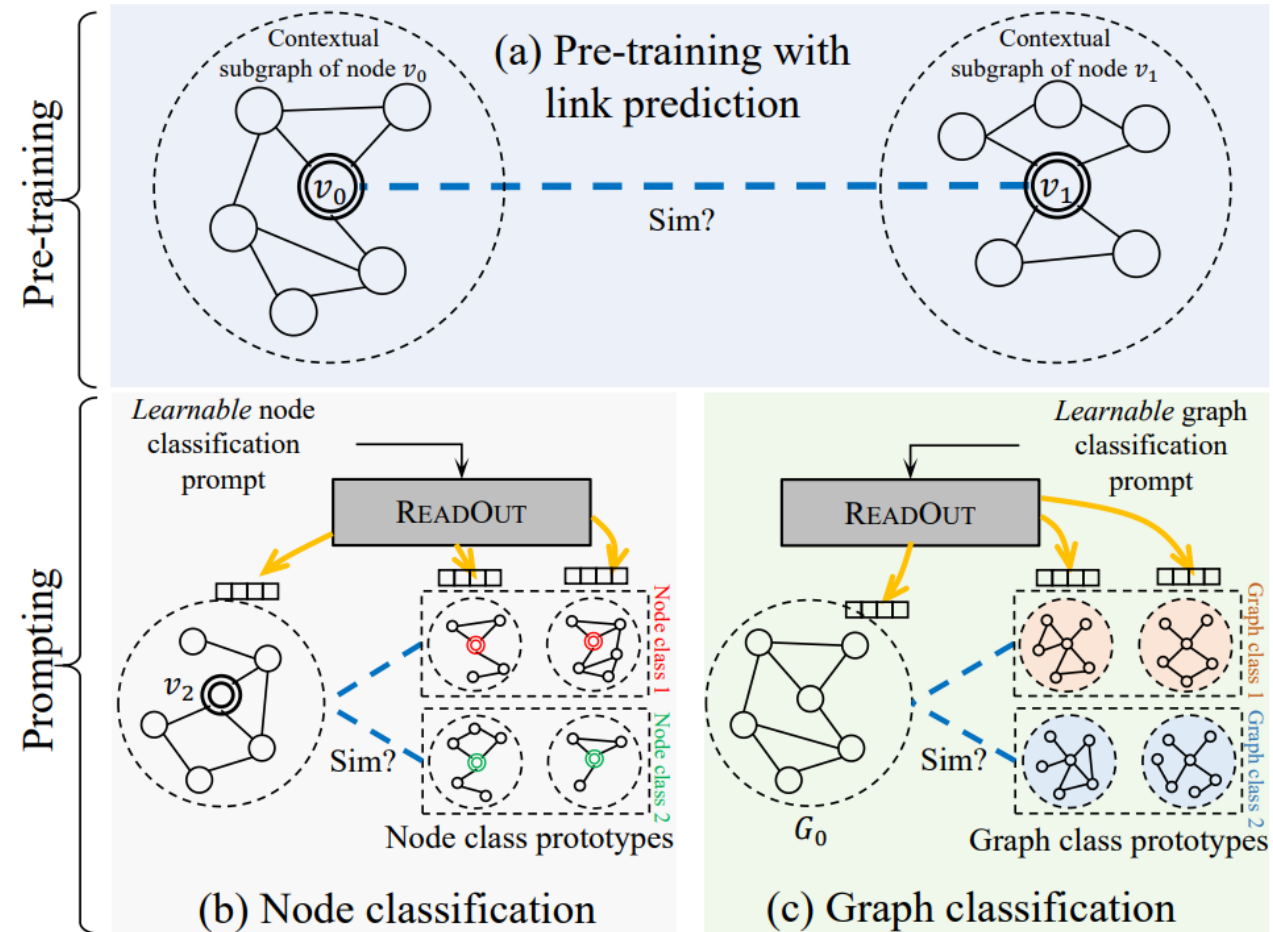



# GraphPrompt: Pre-train, prompt on **graph only**

25

## Unified task template

### Link prediction

Triplet  $(v, a, b)$ , s.t.  $v$  is linked to  $a$ , but not  $b$ :

$$\text{sim}(\mathbf{s}_v, \mathbf{s}_a) > \text{sim}(\mathbf{s}_v, \mathbf{s}_b)$$

### Node classification

$$\ell_j = \arg \max_{c \in C} \text{sim}(\mathbf{s}_{v_j}, \tilde{\mathbf{s}}_c)$$

### Graph classification

$$L_j = \arg \max_{c \in C} \text{sim}(\mathbf{s}_{G_j}, \tilde{\mathbf{s}}_c)$$

All tasks converted to subgraph similarity computation!

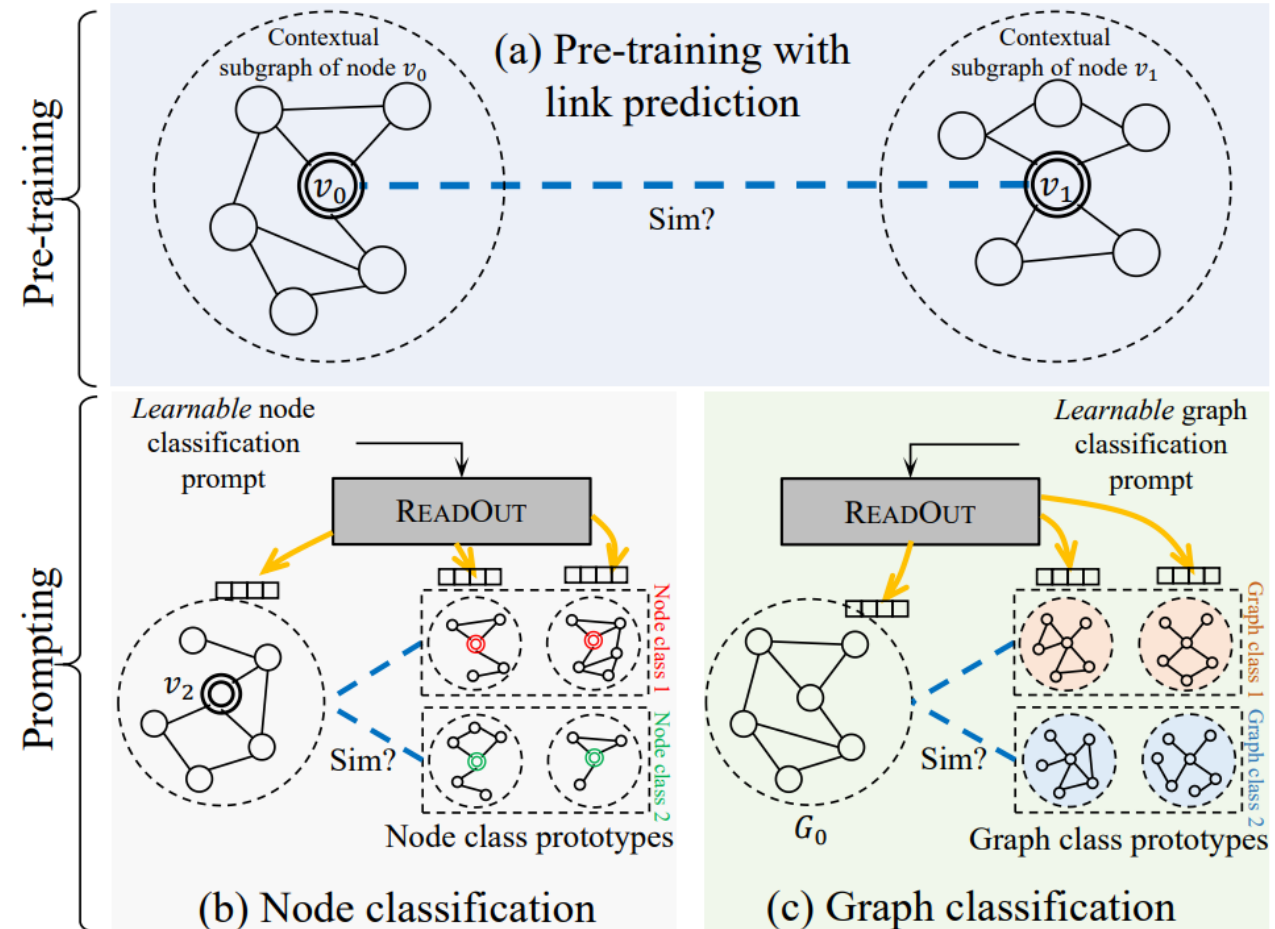

$\mathbf{s}_x$ : (sub)graph embedding of  $x$  ( $x$  is a node or graph)

$\tilde{\mathbf{s}}_c$ : class  $c$ 's prototype (a virtual subgraph, by aggregates all subgraph embeddings in the class)

# GraphPrompt: Pre-train, prompt on graph only

26

## Prompt design

Different downstream tasks require different subgraph readout  
→ Use task-specific learnable prompts

**Prompt vector added to the readout layer of the pre-trained GNN**

$$\mathbf{s}_{t,x} = \text{READOUT}(\{\mathbf{p}_t \odot \mathbf{h}_v : v \in V(S_x)\})$$

$\mathbf{s}_{t,x}$ : (sub)graph embedding of  $x$  for a task  $t$

$\mathbf{h}_v$ : node  $v$ 's embedding vector

$\mathbf{p}_t$  or  $\mathbf{P}_t$ : learnable prompt vector or matrix for task  $t$

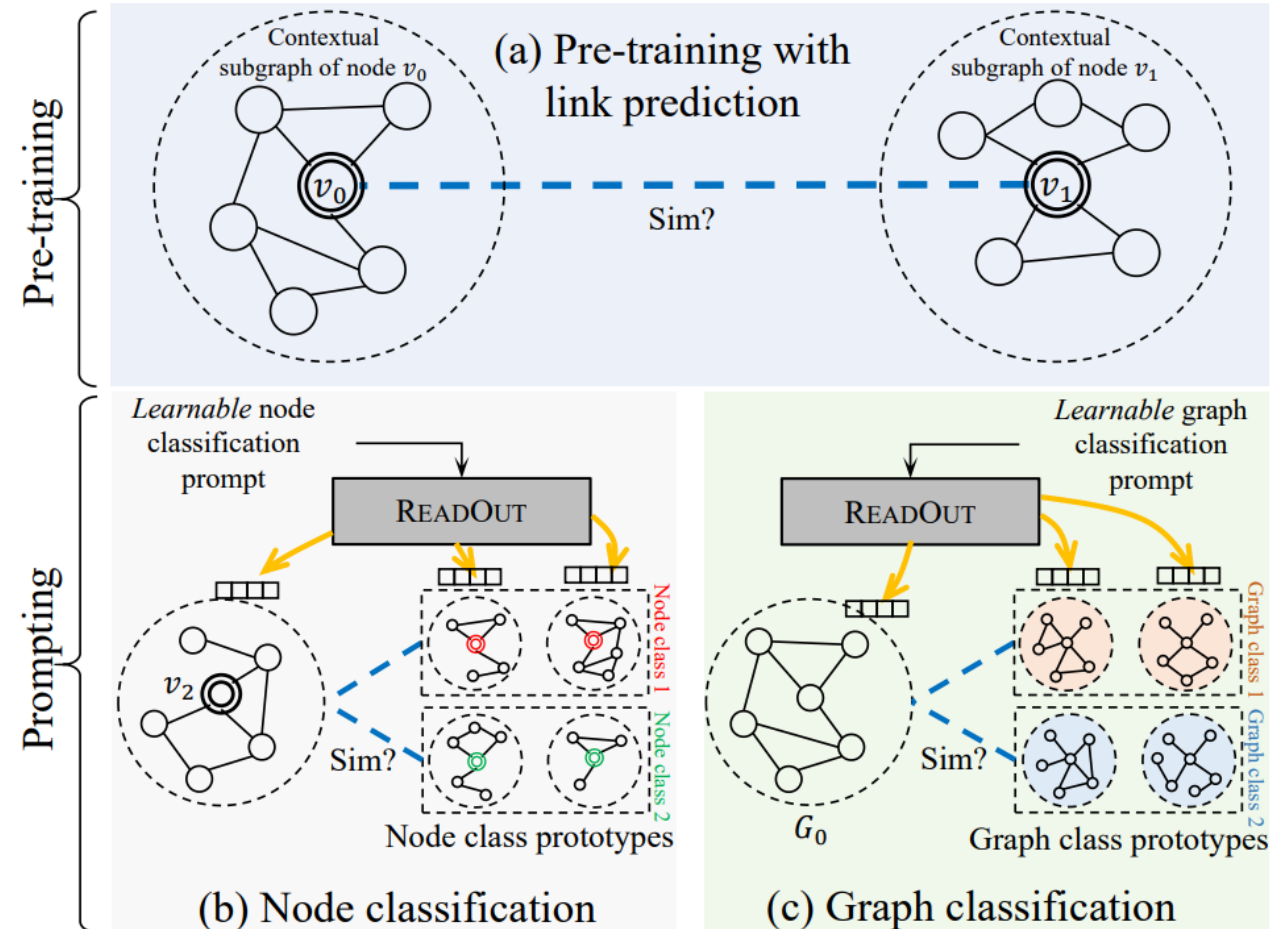

# GraphPrompt: Pre-train, prompt on **graph only**

27

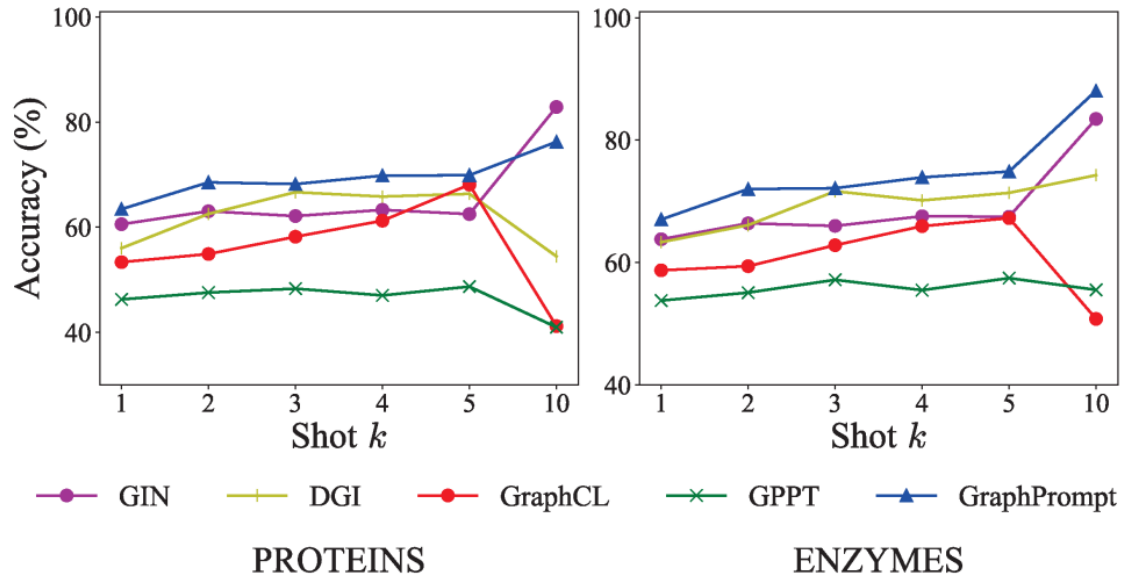

**Impact of shots on few-shot node classification.**

Few-shot: Significantly better

10-shot: Still competitive  
(as graphs are small – 10 shots are a lot)

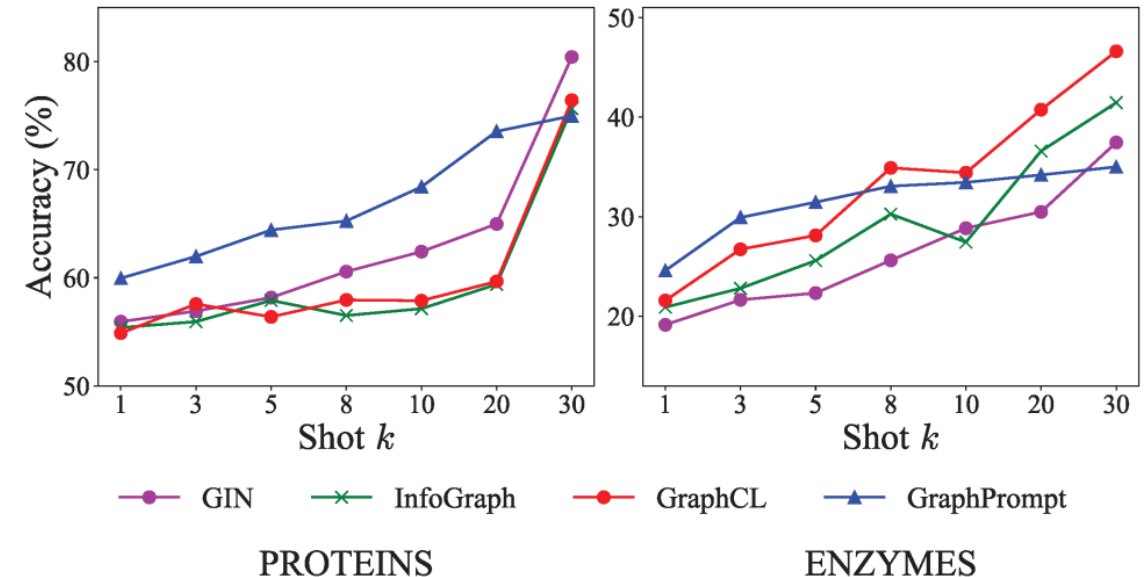

**Impact of shots on few-shot graph classification.**

Few-shot: Significantly better

On ENZYMES: worse performance on  $\geq 20$  shots  
(only 600 graphs – 20 shots/class ~ 20% labels)

# GraphPrompt: Pre-train, prompt on **graph only**

28

## Comparison of parameter efficiency

*Significantly fewer parameters/FLOPs than:*

- *Supervised model (GIN [XHL19]),*
- *“Pretrain, fine-tune” model (GraphPrompt-ft),*
- *Existing prompt model (GPPT [SZH22])*

Methods	Flickr	
	Params	FLOPs
GIN	22,183	240,100
GPPT	4,096	4,582
GRAPHPROMPT	96	96
GRAPHPROMPT-ft	21,600	235,200

Methods	PROTEINS		ENZYMES	
	Params	FLOPs	Params	FLOPs
GIN	5,730	12,380	6,280	11,030
GPPT	1,536	1,659	1,536	1,659
GRAPHPROMPT	96	96	96	96
GRAPHPROMPT-ft	6,176	13,440	6,176	10,944

# Generalized Graph Prompt

29

- Support more pre-training tasks beyond link prediction
  - ▣ DGI, InfoGraph, GraphCL, GCC, ...
- Layer-wise prompts

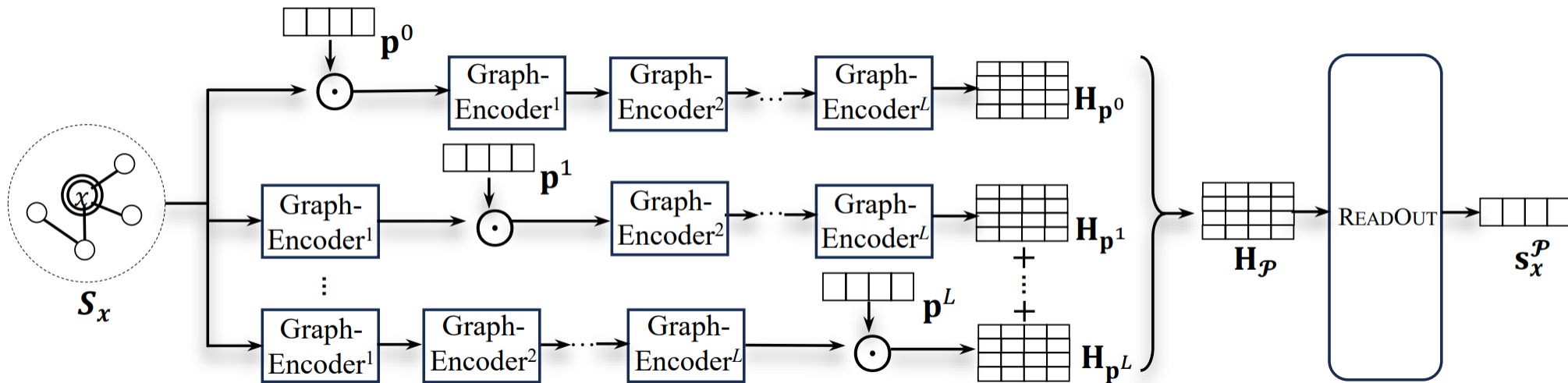

# HGPrompt: Extending to heterogeneous graphs

30

## Two challenges

- Gap between homogeneous and heterogeneous graph
- Different downstream tasks focus on heterogeneous aspect

## Insights

- Dual-template:  
Task + Graph template
- Dual-prompt:  
Feature + Heterogeneity prompt

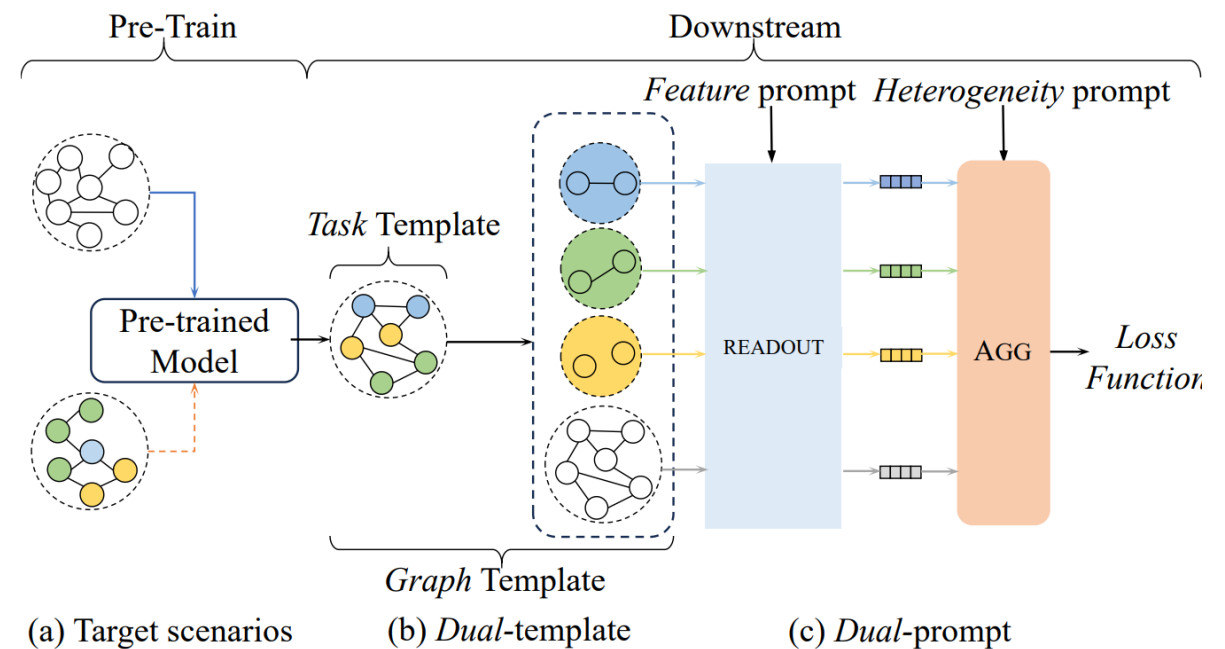

# Outline

31

- Introduction: Data and problems
- Overview of few-shot methodologies
- Can prompt work on graph + text?
- Can prompt work on graph alone?
- **Conclusion**

# Conclusion

32

- Few-shot learning on graphs: different kinds of graphs/tasks
- Learning and transferring/using prior is the key
- Prompt is a promising paradigm...



Jiawei Liu, Cheng Yang, Zhiyuan Lu, Junze Chen, Yibo Li, Mengmei Zhang, Ting Bai, Yuan Fang, Lichao Sun, Philip S. Yu, Chuan Shi. **Towards Graph Foundation Models: A Survey and Beyond.**

<https://arxiv.org/pdf/2310.11829.pdf>



WWW24 Lecture-Style Tutorial: **Towards Graph Foundation Model.**  
Tuesday, May 14, 2024, Half-Day (AM), Singapore  
Chuan Shi, Cheng Yang, Yuan Fang, Lichao Sun and Philip Yu



# Acknowledgement

33

## Student/post-doc co-authors



Zemin  
Liu



Chenghao  
Liu



Zhihao  
Wen



Xingtong  
Yu



Deyu  
Bo

## Main collaborators

Prof. Steven Hoi, Singapore Management University

Prof. Chuan Shi, Beijing University of Posts and Telecommunications

Prof. Xinming Zhang, University of Science and Technology of China

## Main funding sources

- *One-shot learning: A crucial learning paradigm towards human-like learning.* National Research Foundation, Singapore under its AI Singapore Programme (AISG Award No: AISG-RP-2018-001).
- *Learning with less data.* Agency for Science, Technology and Research (A\*STAR) under its AME Programmatic Funds (Grant No. A20H6b0151).
- *Universal pre-training of graph neural networks.* Ministry of Education, Singapore, under its Academic Research Fund Tier 2 (Proposal ID: T2EP20122-0041).
- Lee Kong Chian Fellowship, 2021, Singapore Management University.

# Thank you

35

## Questions?

Email: [yfang@smu.edu.sg](mailto:yfang@smu.edu.sg)

Full publications, codes and data are available at

<http://www.yfang.site/>